

## **NHS IT Strategy - Plan & Support Services**

### **What about the Associated Services?**

#### **An Overview**

**The National Health Service's with more than one million employees, it is the UK's largest employer. It is currently undertaking the UK's largest IT project.**

The national IT strategy, bringing 21st-Century IT infrastructure to the NHS, is a massive overhaul of IT within the health service. Implementation of the strategy started in April 2003. By March 2007, the department expected that the health service will have connected all NHS clinical and management staff to the NHS Network to enable e-mail, directory services and Web browsing. This deadline also applies to the electronic transfer of all biochemistry, haematology and microbiology test results. Long-term objectives of the strategy include broadband access to all NHS clinicians and support staff by December 2005, as well as implementation of domain-to-domain encryption.

A national appointment booking service is projected for implementation by December 2007. This will provide electronic patient records systems in all primary care trusts and hospitals.

A budget of £2.3billion is envisaged.

However, some of this budget will have to be allocated to maintain the IT support services systems, such as dedicated cooling systems, Un-interruptible Power Supply Systems (UPS), Fire Suppression Systems, leak detection and other associated support services. These services are bespoke designed services.

#### **By Eugene Conroy. C.Eng (Eta Projects)**

##### Outline of Support Services Requirements

The requirements set out in the Strategy Plan are briefly as follows: -

For all computer equipment, other than desktop PC's:

- All equipment must reside in temperature controlled environments.
- Units providing cooling have fully redundant capacity.
- All equipment should be physically secure with controlled staff access.
- All security measures should comply with the BS7799 Standard.
- All clinically critical systems must have UPS and alternative power provision.
- Critical systems include Routers, Switches, and Servers etc.
- Equipment must reside in an environment with appropriate fire protection systems.

Unless these services are designed correctly, IT systems will suffer as irreparable damage can result on disk drives if the equipment is exposed to excessive temperature.

It is essential that support services are designed to provide N+1 redundancy. I.e. should any one-unit fail; the remaining unit should be designed to cater for the design load of the equipment, including planned expansions in the future.

Also, when equipment fails or malfunctions for any reason, immediate notification is required to enable action to be taken before a critical situation arises.

The Hammersmith Hospital NHS Trust has recently upgraded their main IT room to meet the demands of the increased IT infrastructure and is currently in the process of upgrading the associated services in the secondary IT Comms Rooms, to ensure the integrity of their IT systems at all times.

This article provides an overview of the upgrade works at the Trust. It may be of interest to IT managers who are undertaken IT room upgrades.

#### Hammersmith Hospital Trust

The Hammersmith Hospital NHS Trust IT backbone system comprises of one large IT room with several secondary comms rooms strategically located around the Trust other sites. This comprises of three main hospital sites located in the region of West London.

Eta Projects were commissioned by the Trust to undertake a risk assessment of each site and prepare a scope of upgrade works to meet the expanding demand of the IT infrastructure.

Eta Projects have carried out similar projects of this specialist nature for major financial institutions in the City of London and national Telecommunication companies.

The critical services associated with IT rooms are as follows:

#### UPS System.

UPS systems are a minefield to the uninitiated and due to the critical function, it is imperative that these are selected correctly and designed into the electrical infrastructure to provide maximum capacity and resilience at all times.

A new 2 x 120kVA UPS system was installed to replace the original system, which was dated and due to load increase had lost its N+1 capacity. Costs studies were carried out and it was found to be more cost effective to completely replace, rather than upgrade the existing UPS system. This enabled the latest UPS technology to be utilised. The new UPS modules are configured in parallel redundancy, each sharing the load equally but each rated to carry the full load if necessary.

In summary, UPS systems should be specified as 12-pulse or better, double conversion, true on-line technology and be rated for a "Crest Factor" of 3-1 minimum. The system should be complete with a "Mains" wrap around by pass arrangement. The arrangement at the hospital was configured as shown in figure No 1: -

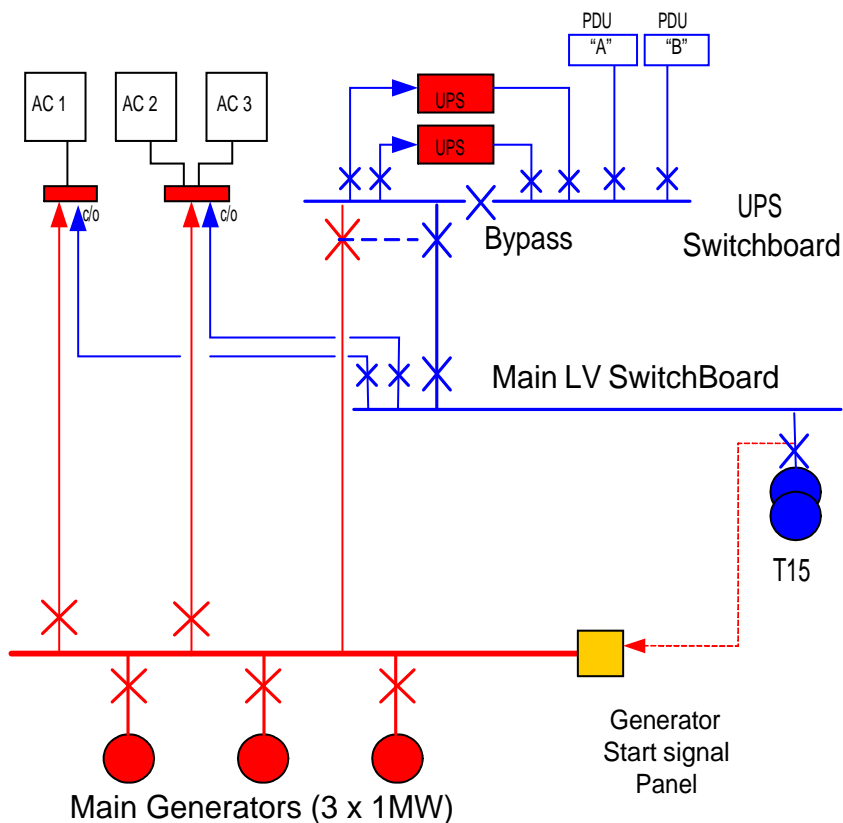

**Figure No 1 (UPS Distribution System)**

UPS Main Electrical Distribution System.

The UPS systems were designed for maximum resilience and flexibility. The UPS distribution was designed with a “Mains” Wrap around bypass systems to enable the end user to bypass the UPS modules with “No-Break” in the event of a catastrophic failure of the UPS system. Dual modules with facilities for an additional module to be added are provided on the switchboard to ensure the N+1 redundancy is maintained even with future load increases. The switchboard was manufactured to Form 4/2

The UPS distribution is fitted with intelligent power meters, which are linked to the hospital central power monitoring system. These are configured to activate alarms when pre-determined values are exceeded.

In addition, the UPS distribution is fitted with Surge Protection units.

One of the most important elements of the UPS systems is the final means of distribution to the IT cabinets. IT rooms are a constant changing environment and any distribution system should be designed for flexibility and future additions and modifications. Therefore, the power distribution unit (PDU) is specifically designed for this purpose as follows: -

Power Distribution Unit (PDU)

The power distribution Unit is designed for “Live” working and suitable for mounting on a raised floor detail. Cabling to the individual IT cabinets was carried out using 3-core armoured cable terminating in Commando type socket outlets.

The miniature circuit breakers should ideally be TYPE 4 and should be mounted on a pan assembly with facility for isolation supply to each breaker. This enables breakers to be changed/up-rated in the future if required. This also enables future power cabling modifications without the need for isolations and loss of critical systems.

## Earthing

Correct earthing of IT rooms is essential and the earthing demands are different to conventional electrical installations. Under normal operation, IT equipment incurs earth-leakage currents, the magnitude of which varies between individual items of equipment. Whilst the magnitude of current from individual items of equipment is small, the accumulation of current from equipment in a stacked cabinet may be of sufficient magnitude to operate earth leakage protective equipment. Therefore, additional "System Earthing" over and above "Equipotential Earthing" is required. Therefore, both system and equipotential earthing should be provided. This can be provided either with an Earth Mat to which each cabinet is connected to form an Equipotential earth system or alternatively use the Armour from each SWA cable as the Equipotential Earth and the third inner core of the cable as the "System Earth" Refer to the Figure No 2. This method ensures that star earth formation is maintained and that the IT cabinet is afforded equipotential earth at all times.

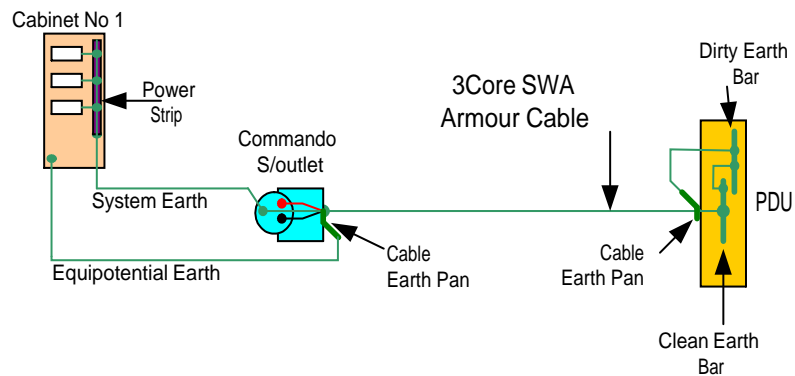
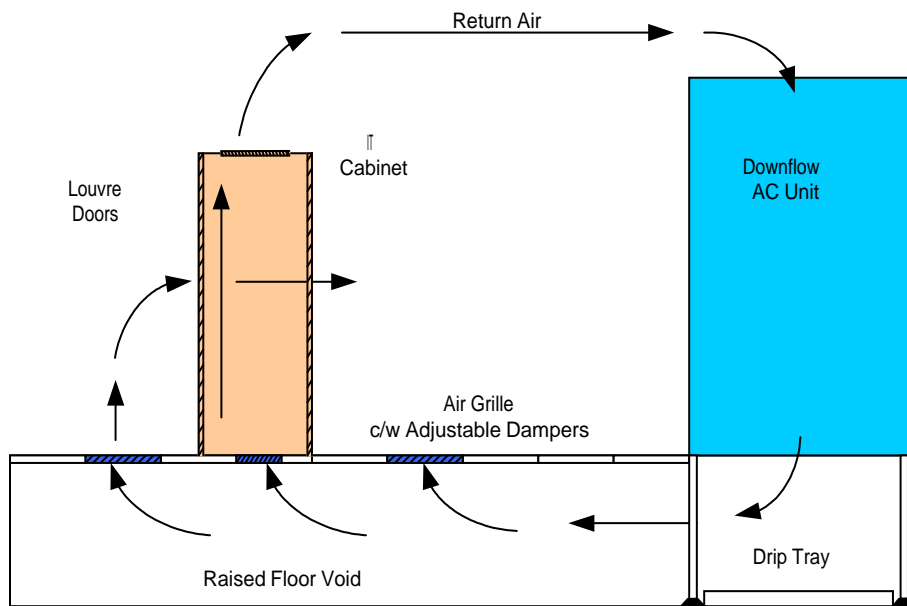

**Figure No 2 (Earthing System)**

### Air Conditioning Systems

The cooling systems for the IT environment are critical in IT rooms, as a sudden increase in temperature can be detrimental to the sensitive disk drives. Even if they do not fail immediately on excessive temperature rises, failures are known to occur shortly after recorded temperature rises as drives suffer warping.

The Air Conditioning systems should be of the “Down Flow” type with modules designed for raised floor use. These operate on the principle of pressurising the floor void. Opening the floor below the cabinet allows the cooled air to rise through the cabinet and this draws the hot air up and through the equipment. Refer to figure No 3



**Figure No 3 (Air Conditioning System)**

The air conditioning modules should be specified with dual circuits to maximise resilience and air flow throughout the computer room. This approach will also enable optimum energy saving as each circuit is switched in as required. In this case 3x40kW sensible cooling units were installed.

In addition, the IT department should be advised that all cabinets should be specified with either louvered or slotted front or rear doors. The majority of IT equipment is now designed for forced airflow through the equipment. Therefore, the conventional theory of rising heat in the cabinet is no longer always applicable.

The air conditioning is provided with both a “Mains” and “Generator” standby power supply. The changeover unit for the original UPS system was utilised for the air –conditioning system and the arrangement can be seen in figure No 1. The air conditioning systems are configured to relay alarm signals to the IT department via a dedicated Control and Monitoring systems as follows: -.

## Control and Monitoring

Due to the sensitive environmental conditions require and the critical nature of the IT systems, close environmental control and monitoring of the space is required.

Unless carefully planned and executed, this can mean elements either missed or inadequate provisions made. Also, systems are sometimes installed under different programmes and therefore difficult to carry out a commissioning programme at the same time.

Eta Projects overcome this obstacle by insisting that all available alarms are wired out to an independent "Alarm Interface Joint box" This enables each independent company to progress their works unhindered i.e. AC, UPS, Fire systems etc.

As each system is completed, the alarms are proved between the equipment and the joint box and witnessed by the commissioning/ project manager.

The alarm from each air-conditioning unit and other critical support systems are relayed to the Trust IT department via an SNMP module. Alarms are also relayed to a conventional alarm indicator module located at the IT department IT helpdesk. The SNMP system transmits e-mail alerts of alarm conditions to nominated persons and these are also transmitted to Eta Projects office. This enables system monitoring to be implemented long after the hand over has taken place.

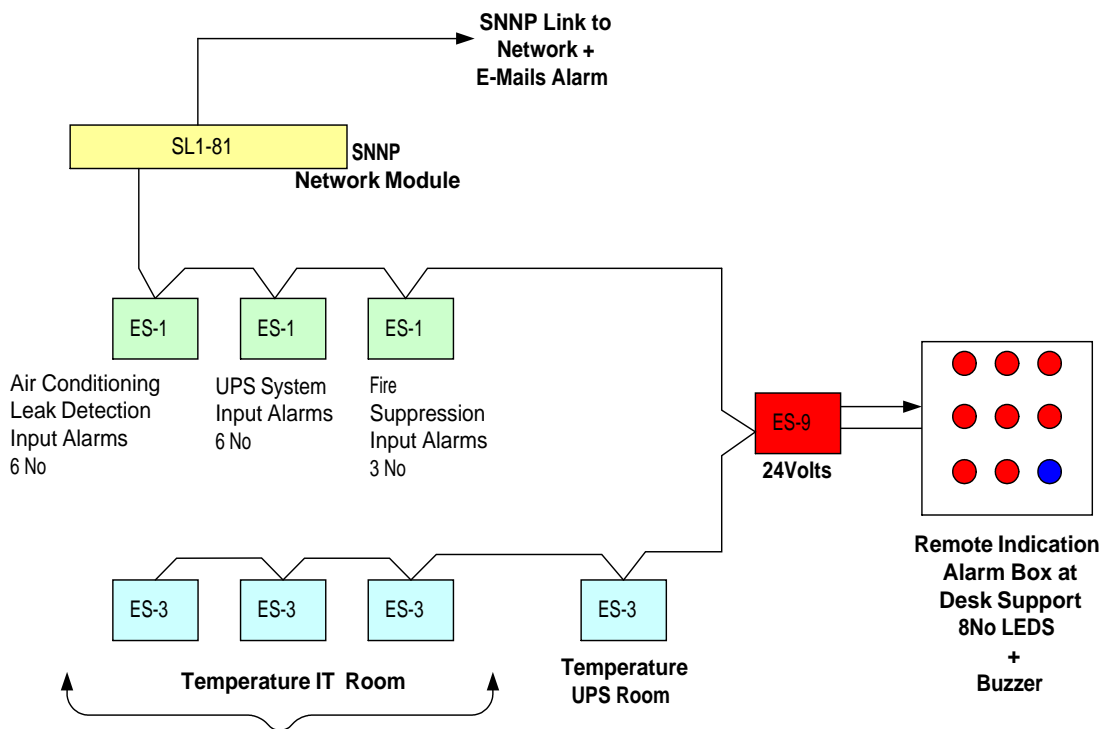

Figure No 4 (Control & Monitoring System)

## Fire Suppression / Detection Systems

Fire suppression systems in current use today tend to be either FM200 or Inergen systems. However, in some Data Centres, fine mist spray is sometimes used. There is no legal obligation to install fire suppression systems. However, there is a requirement to provide fire detection system, which is completely different. The requirement for fire suppression systems is a recommendation and is usually dictated by the insurers.

In addition, consideration should be given to the installation of "Very Early System Detection Alarm" (VESDA). These are air-sampling systems where the air from the environment is drawn into a narrow pipe, which is porous, and through an extremely sensitive sampling chamber. The pipe is usually mounted directly over the return air chamber of the air conditioning down-flow units.

Where fire suppression systems are installed, the area should be subjected to a room pressurisation test to ensure the integrity of the fire enclosure and that the suppression gas will be contained for sufficient time to quench the fire condition.

Subsequent to any fire, the area will have to be cleared of smoke, which is the main cause of death. Also, if the fire suppression agent has been released into a protected area, the suppression gas will have to be purged as depending on the agent used, the gas itself may be considered detrimental to health. Early consultation with the Local Authorities will enable guidance to be sought.

Also, if suppression systems are installed, it is imperative that consultation is made with the local authorities as follows: -

### Local Authority District Surveyor and Fire Officers Approvals

It is imperative that all works are carried out to the approval of the Local Authorities and meet Fire Officer's approval. Basically, the approval requirements are as follows: -

<a href="#">Planning Officer</a>	Works to external façade of building. i.e. AC Condensers, Generators etc.
<a href="#">Environmental Officer</a>	Work's generating noise nuisance such as AC Condensers, Generators etc
<a href="#">Fire Officer</a>	Works that cause fire hazard and that affect escape from buildings
<a href="#">District Surveyor Officer</a>	Works that cause fire hazard and that affect escape from buildings

The District Surveyor Officer some times acts as the conduit to the Fire Officer and will also give approval to smoke extract/gas suppression extract and fresh air systems that are installed in protected IT rooms.

### Smoke Extract / Supply Air systems.

As IT/Data rooms are considered as areas generally unoccupied, the requirement for fresh air is not as stringent as those areas, which are generally occupied. However, some minimum fresh air should be provided. Also, extract air should also be provided especially if UPS systems are installed which have standby batteries.

However, the fresh air and extract air systems need to be isolated in the event of fire detection and prior to the release of the suppression gas, Otherwise its effectiveness will be impaired. Therefore, a damper control panel will be required which will "Operate to Close" motorised dampers on both the fresh air and extract air ductwork system prior to the gas release. At the same time it should be configured to "Operate to Open", corresponding dampers on the dedicated gas extract ductwork and start the extract fan, if smoke extract mode is selected.

## Flooring

The flooring arrangement plays an important part of any IT room. The flooring should be of the heavy-duty, raised floor type with anti-static vinyl type floor tiles. The raised flooring should be a minimum of 350mm high to allow for proper cable management systems to be in place and provide the necessary clearance to maintain the correct air flow pressure from the air conditioning down-flow systems.

The floor should be complimented with a number of floor grilles, which should be of the variable air Volume type. These enable correct balancing of the air flow to the IT room to cater for hot spots and maintain a constant temperature throughout the room.

## Leak Detection

All IT rooms should be afforded leak detection due to the high level of risk from water ingress. This can either from external sources or from the condense water generated by the air conditioning units. Systems should be selected that provide simple but clear indication of the exact source of the leak.

The system should be complete with volt free contacts to enable remote alarm indication of the presence of a water leak. In this case, the alarms are transmitted to the IT room help-desk and Eta Projects Offices via the SNMP alarm monitoring system.

## Procurement

The IT room upgrade works were carried with Eta Projects acting as project manager. The main systems such as Air Conditioning and UPS systems were procured under sealed bid tender with orders placed directly by the Hospital. This saved the add-on "Profit and Overhead" costs from a sub-contractor.

The main challenge imposed on the financial management of the contract was the VAT element implication of individual elements.

Unfortunately, the NHS is not considered as a traditional business, where VAT is concerned. Only certain elements of work carried out are VAT deductible. Therefore, it is critical to establish if the budget available to carry out works is Net or Gross values. In addition, it is important to identify on the invoices each element under the various VAT classifications agreed between the NHS and the VAT office. Otherwise, the hospital accounts department may be unaware that some elements of works are deductible and unnecessary VAT will be imposed.

For the record all professional fees are VAT deductible and other works that could be described as repairing by replacement of existing systems.

## Recommendations

Designers and project Managers should consider the following recommendations:-

- 1.0 12-Pulse or improved UPS Technology should be specified
- 2.0 UPS systems should be designed to operate at 0.8 leading and lagging power factor
- 3.0 IT Cabinets should be installed with ventilated front and rear doors
- 4.0 Individual (Dual) 30amp supplies should be presented at each cabinet
- 5.0 Individual earth bond should be provided at each cabinet
- 6.0 Air Conditioning down-flow units should be twin circuit designed for N+1 operation
- 7.0 Power distribution units should be designed fro "Live" working
- 8.0 Appropriate control and remote monitoring should be provided
- 9.0 Power monitoring should be provided to include both energy and power quality monitoring
- 10.0 Consideration should be given to Local Authority approvals process